

PROGRESS REPORT:

Harmful Algal Bloom Dynamics in the Gulf of Maine

Student: Jennifer Brown

Advisor: Dr. Fei Chai

Reporting Period: June 16-20, 2008

Background

So far in the project, I have read various background materials recommended by Dr. Chai (summarized in “Project Summary” on the project homepage at http://arch.eece.maine.edu/superme/index.php/Hab_modeling). I constructed a simplified box model using Stella software which simulated phytoplankton, zooplankton, nutrient, and *Alexandrium fundyense* parameters. Last week (Week Three), I began to construct framework for a 10-box Harmful Algal Bloom (HAB) / Gulf of Maine model in Stella. This framework added complexity to a 5-box model that I finished last week. New changes included dividing the phytoplankton parameter into “large” and “small” groups, dividing the zooplankton into “micro” and “meso” groups, and dividing the nutrient parameter into nitrate, ammonium, and silicate groups. I included real-life data for water temperature and salinity from the GoMOOS program website, and set a lower bound on the *Alexandrium fundyense* population to keep it from crashing during simulation. This week’s goal was to finish constructing the 10-box model and to begin running simulations with it.

Work Completed

Over the course of the week, I finished constructing the 10-box model and began to run it in Stella. I used equations listed in work by McGillicuddy et al. to construct algorithms for *Alexandrium fundyense*, and equations from work by Chai et al. to model the rest of the Gulf of Maine ecosystem. I continued to use daily average water temperature and salinity data from GoMOOS from the past year, repeated three times for the three-year simulation. I currently still need to download three years of continuous data from GoMOOS to replace the one-year, repeated data.

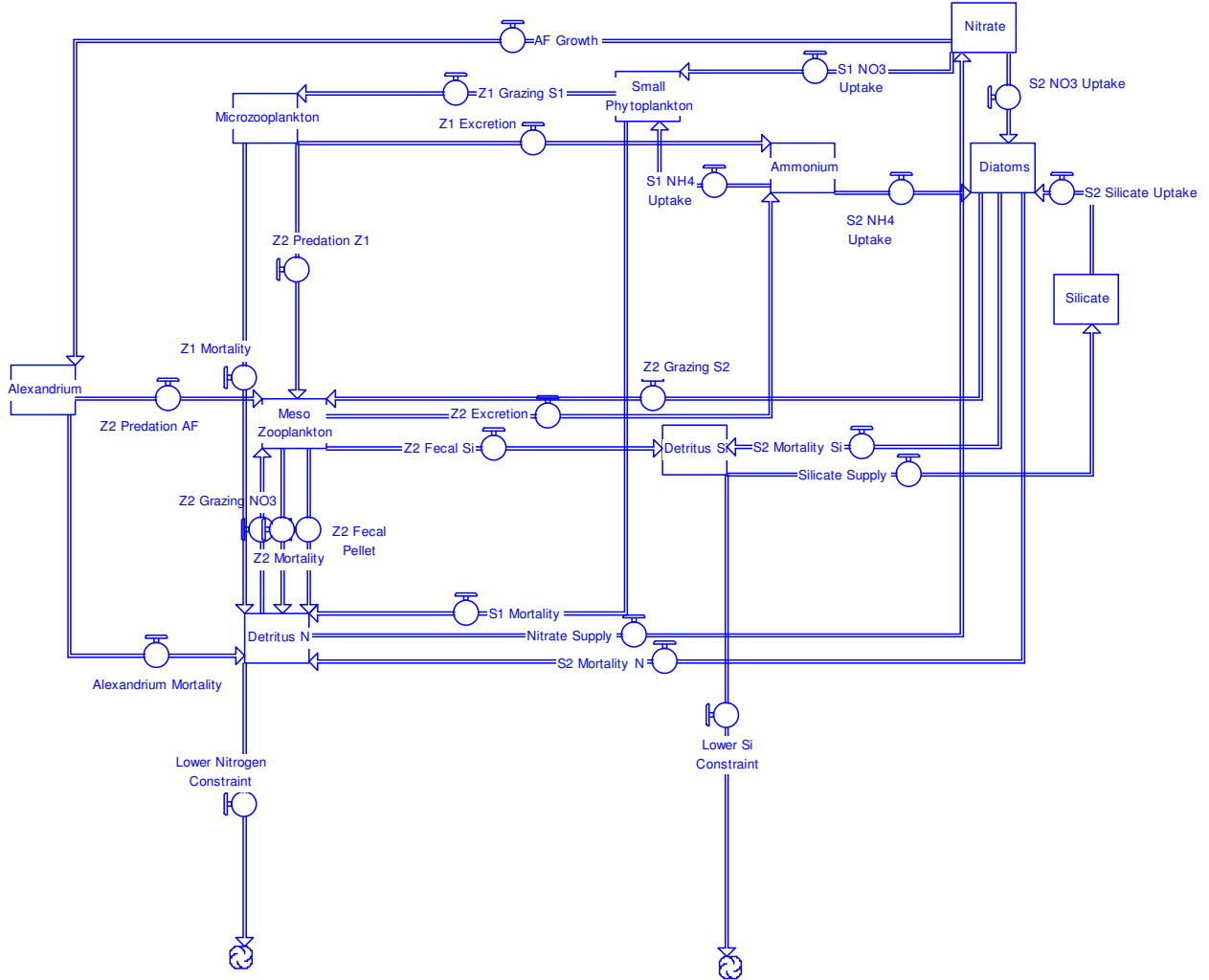

Figure 1: Basic framework for Stella 10-box model. Abbreviations: S1-Small Phytoplankton; S2-Diatoms; AF-Alexandrium fundyense; Z1-Microzooplankton; Z2-Mesozooplankton.

To construct the Stella 10-box model, I began with a basic framework of interactions between species and components of the Gulf of Maine ecosystem (Fig. 1). I then added algorithms concerning *A. fundyense* growth (Eq. 1-6), where T is water temperature, S is salinity, and E is available light (McGillicuddy et al.).

$$f(T) = -0.000347T^3 + 0.0097T^2 - 0.0133T + 0.131 \quad R^2 = 0.88. \quad (1)$$

$$f(S) = -0.0022S^2 + 0.103S - 0.195 \quad R^2 = 0.66. \quad (2)$$

$$\mu(T, S) = \mu_{\max} \times f(T) \times f(S). \quad (3)$$

$$\mu(E, T, S) = (\mu(T, S) + \mu_0^r) \tanh\left(\frac{\alpha_g E}{(\mu(T, S) + \mu_0^r)}\right) - \mu_0^r, \quad (4)$$

$$\mu(\text{NO}_3, T, S) = \mu(T, S) \times \frac{[\text{NO}_3]}{K_N + [\text{NO}_3]}. \quad (5)$$

$$\mu(E, \text{NO}_3, T, S) = \min(\mu(E, T, S), \mu(\text{NO}_3, T, S)). \quad (6)$$

Next, I added algorithms concerning the interactions within the marine ecosystem (Chai et al.). Nitrate uptake by small phytoplankton (NPS1) is given by

$$\text{NPS1} = \mu_{1\max} \frac{\text{NO}_3}{K_{\text{NO}_3} + \text{NO}_3} e^{-\psi \text{NH}_4} (1 - e^{-(a/\mu_{1\max})I}) \text{S1} \quad (7)$$

NO_3 uptake by S1 NO_3 regulation NH_4 inhibition light regulation

$\mu_{1\max} = 2.0 \text{ day}^{-1}$ (maximum specific growth rate of small phytoplankton),
 $\psi = 5.59 \text{ (mmol m}^{-3}\text{)}^{-1}$ (ammonium inhibition parameter),
 $K_{\text{NO}_3} = 0.5 \text{ mmol m}^{-3}$ (half-saturation for nitrate uptake by S1).
 $\alpha = 0.025 \text{ (W/m}^2\text{)}^{-1} \text{ day}^{-1}$ (initial slope of $P-I$ curve),

In Eqs. 7-10, I edited the light regulation parameter in the model to be Available Light/($I_k + \text{Available Light}$), where I_k is a light saturation parameter. This change in the parameter is due to the fact that the model is in 2-D rather than 3-D, and the irradiance in the original equation (7) depends on a third dimension which doesn't exist in my model. Thus, it was necessary to use a 2-D parameter.

Ammonium uptake by small phytoplankton is given by

$$\text{RPS1} = \mu_{1\max} \frac{\text{NH}_4}{K_{\text{NH}_4} + \text{NH}_4} (1 - e^{-(a/\mu_{1\max})I}) \text{S1} \quad (8)$$

NH_4 uptake by S1 NH_4 regulation light regulation

$K_{\text{NH}_4} = 0.05 \text{ mmol m}^{-3}$ (half-saturation for ammonium uptake by S1)

Silicate uptake by diatoms is given by

$$\text{NPS2} = \mu_{2\max} \frac{\text{Si(OH)}_4}{K_{\text{Si(OH)}_4} + \text{Si(OH)}_4} (1 - e^{-(a/\mu_{2\max})I}) \text{S2} \quad (9)$$

silicate uptake by S2 Si(OH)_4 regulation light regulation

$\mu_{2\max} = 3.0 \text{ day}^{-1}$ (the potential maximum specific diatom growth rate),
 $K_{\text{Si(OH)}_4} = 3.0 \text{ mmol m}^{-3}$ (half-saturation for Si(OH)_4 uptake by S2).

The ammonium uptake for diatoms is given by

$$\text{RPS2} = \mu_{2\max} \frac{\text{NH}_4}{K_{\text{S2-NH}_4} + \text{NH}_4} (1 - e^{-(a/\mu_{2\max})I}) \text{S2} \quad (10)$$

NH_4 uptake by S2 NH_4 regulation light regulation

$K_{\text{S2-NH}_4} = 1.0 \text{ mmol m}^{-3}$ (half-saturation for ammonium uptake by diatoms)

Microzooplankton grazing rate on small phytoplankton is given by

$$G_1 = G_{1\max} \frac{\text{S1}}{K_{1\text{gr}} + \text{S1}} \frac{\text{S1}}{\text{S1}_{\text{ave}}} Z1 \quad (11)$$

food limitation depth modification

$G_{1\max} = 1.35 \text{ day}^{-1}$ (microzooplankton maximum growth rate),
 $K_{1\text{gr}} = 0.5 \text{ mmol m}^{-3}$ (half-saturation for microzooplankton ingestion).

Because the 10-box model is 2-D, the depth modification parameter in (11) is omitted from my own algorithm.

Mesozooplankton grazing rates on diatoms, microzooplankton, and detrital nitrogen, respectively, are given by

$$G_2 = G_{2\max} \frac{\zeta_1 \text{S2}}{K_{2\text{gr}} + \zeta_1 \text{S2} + \zeta_2 \text{Z1} + \zeta_3 \text{DN}} Z2 \quad (12)$$

$$G_3 = G_{2\max} \frac{\zeta_1 \text{Z1}}{K_{2\text{gr}} + \zeta_1 \text{S2} + \zeta_2 \text{Z1} + \zeta_3 \text{DN}} Z2 \quad (13)$$

$$G_4 = G_{2\max} \frac{\zeta_1 \text{DN}}{K_{2\text{gr}} + \zeta_1 \text{S2} + \zeta_2 \text{Z1} + \zeta_3 \text{DN}} Z2 \quad (14)$$

$G_{2\max} = 0.53 \text{ day}^{-1}$ (mesozooplankton maximum growth rate),
 $K_{2\text{gr}} = 0.25 \text{ mmol m}^{-3}$ (half-saturation for mesozooplankton ingestion),
where $\zeta_1, \zeta_2,$ and ζ_3 are the preferences for a given food type, and defined as following:

$$\zeta_1 = \frac{\rho_1 \text{S1}}{\rho_1 \text{S1} + \rho_2 \text{Z1} + \rho_3 \text{DN}}$$

$$\zeta_2 = \frac{\rho_2 \text{Z1}}{\rho_1 \text{S1} + \rho_2 \text{Z1} + \rho_3 \text{DN}} \quad (15)$$

Dr. Chai suggested grouping the box parameters into three categories (Nitrogen-related parameters, Silica-related parameters, and Unavailable [Lower] Nutrients), which would clean up the look of the model considerably. Grouping parameters might save some time and lessen the probability of human error occurring. My current 10-box model ran the simulation well, but I will make a grouped model next week and compare the simulation results as a way of checking for error.

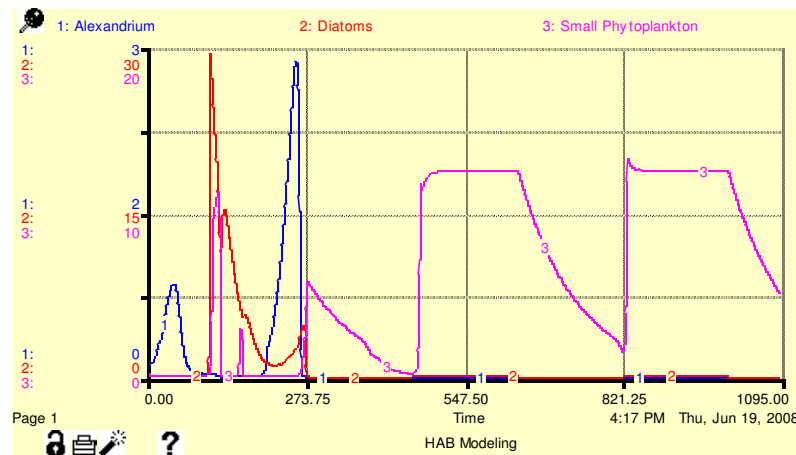

Figure 3: Irregular Small Plankton population take-over with sawtooth pattern

Another problem I encountered is similar to the “*A. fundyense* population crash” problem I had during Week Two. Initially, all species populations except Diatoms and Small Phytoplankton crashed in simulations of the 10-box model. I set lower bounds for all populations, in the same way that I set a lower bound for *A. fundyense* during Week Three. Now my model runs one year-long cycle of blooms for all species before giving way to only Small Phytoplankton (Fig. 3). The small phytoplankton takes over during the simulation with an odd sawtooth pattern, which is not a smooth graph, as it should be. This leads me to believe that there is a bug in my model, since I read about correcting a sawtooth simulation in the Stella Help Guide several days earlier.

During Week Five, I will correct the modeling error that causes the Small Phytoplankton to take over the simulation with a sawtooth pattern. I will then work on adding an *A. fundyense* germination parameter to the model. Then I can run full 2-D simulations and create visualizations for the output.

References

Chai, F., R. C. Dugdale, T-H Peng, F. P. Wilkerson, and R. T. Barber (2002): One Dimensional Ecosystem Model of the Equatorial Pacific Upwelling System, Part I: Model Development and Silicon and Nitrogen Cycle. Deep-Sea Res. II, Vol. 49, No. 13-14, 2713-2745.

McGillicuddy Jr., D.J., D.M. Anderson, D.R. Lynch, D.W. Townsend (2005). Mechanisms regulating large-scale seasonal fluctuations in *Alexandrium fundyense* populations in the Gulf of Maine: Results from a physical–biological model. Deep-Sea Res. II 52 (19-21): 2698-2714.